



HOV32K1A000

- Indoor / Outdoor installations
- Side opening, easy camera servicing
- Weatherproof standard IP66 (with cable glands or with optional sealing rings)
- Built-in wiper option
- Different mounting options: standard bracket, cable management bracket or P&T

Innovative and stylish housing, designed to simplify installation and servicing, HOV ensures total protection against all environmental conditions. Due to its side opening, the accessibility to the camera, lens and all its connections is made far easier.

Its weatherproof features are ensured by neoprene-rubber gaskets and 2 PG9 + 1 PG11 cable glands with their specific gaskets, or by the sealing gaskets, when installed with bracket with internal cable management.

The body is made of die-cast aluminium; the sunshield of ABS material. The sunshield with its integrated edge-protector offers good thermal insulation. HOV offers the possibility of various mountings: wall or ceiling brackets, standard or full cable management brackets, or Pan & Tilt heads.

The housing can be equipped with a built-in, self-parking wiper. The wiper does not interfere with the viewing range of the installed camera.

A specific version with a very efficient cooling system is available for installation with IP cameras and for high environmental temperature.

A wide range of accessories is available, including sunshield, heater and fan-assisted heater, blower and camera power supply, wiper and alarm tamper switch.

These accessories are supplied as a simple plug-in kit for easy installation or factory-installed.



HOV32D0A000 + WBOVA2

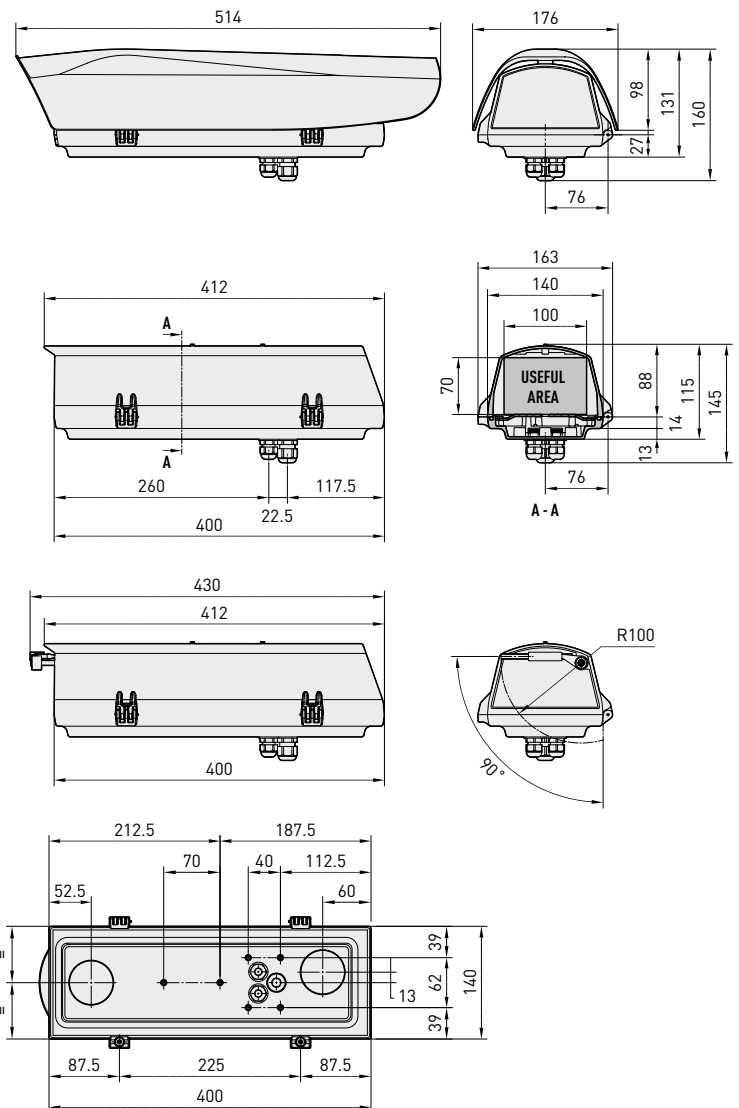

The values are in millimeters.

Model	Sunshield	Heater 115/230V AC	Heater 12V DC/24V AC	12V DC blower with double air exchange filter	24V AC blower with double air exchange filter	PS IN 100/240V AC, OUT 24V AC, for blower with double air exchange filter	Wall mount WBOVA2	Wiper 24V AC	Wiper 230V AC	Max consumption
HOV32D0A000										
HOV32K0A000	•									
HOV32K0A016	•				•					4W
HOV32K0A017	•			•						4W
HOV32K0A018	•					•				15W
HOV32K0A100	•							•		7W
HOV32K0A147	•				•			•		11W
HOV32K0A200	•							•		7W
HOV32K1A000	•	•								40W
HOV32K1A018	•	•				•				44W
HOV32K1A085B	•	•					•			40W
HOV32K1A100	•	•							•	47W
HOV32K2A000	•		•							20W
HOV32K2A016	•		•*		•					24W
HOV32K2A017	•		•*	•						24W
HOV32K2A085B	•		•				•			20W
HOV32K2A147	•		•*		•			•		31W
HOV32K2A200	•		•*					•		27W

* The housing must have the same supply as the blower.

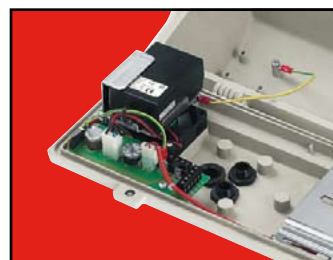

TECHNICAL DATA

GENERAL

Die-cast aluminium
Sunshield in ABS
Epoxypolyester powder painted colour RAL9002
Stainless steel external screws
Supplied with instruction manual, desiccant bag, accessories for camera and lens mounting

MECHANICAL

3 removable cable glands: 2xPG9 and 1xPG11
Glass window (BxH): 118x75mm (4.6x2.7in)
Internal usable area (BxH): 100x70mm (3.9x2.7in)
Internal usable length with and without accessories: 250mm (9.8in)

ELECTRICAL

Heater Ton 15°C+/-3°C (59°F +/-5°F) Toff 22°C+/-3°C (71°F +/-5°F)

- IN 12V DC/24V AC, consumption 20W max
- IN 115/230V AC, consumption 40W max

Heater fan assistant, continuous duty

- IN 12V DC, consumption 4W max
- IN 24V AC, consumption 4W max
- IN 100-240V AC, consumption 4W max, with wide range power supply IN 100-240V AC/12V DC

Blower kit with thermostat Ton 35°C+/-3°C (95°F+/-5°F) Toff 20°C+/-3°C (71°F+/-5°F) for version with double filter

- IN 12V DC, consumption 4W max
- IN 24V AC, consumption 4W max

Camera power supply

- IN 100-240V AC - OUT 12V DC, 50/60 Hz, 1A
- IN 230V AC - OUT 24V AC, 50Hz, 400mA

Integrated Wiper

- IN 230V AC, consumption 7W max
- IN 24V AC, consumption 7W max

ACCESSORIES

OH0VS32A000	Sunshield
OH0VH1	Heater 115/230V AC
OH0VH2	Heater 12V DC/24V AC
OH0VV1	Heater fan assistant, continuous duty, IN 12V DC
OH0VV2	Heater fan assistant, continuous duty, IN 24V AC
OH0VV3	Heater fan assistant, continuous duty, IN 100/240V AC
OH0VPS1B	Wide range camera power supply IN 100-240V AC - OUT 12V DC

OH0VPS2B	Camera power supply IN 230V AC - OUT 24V AC
OH0VTA1	Tamper switch on board with tamper proof screws and key
OHEGBB	Weatherproof junction box IP55

RELATED PRODUCTS

WBJA	Wall bracket with ball joint
WBOVA2	Wall bracket with internal cable channel
WBOV3A2	Wall bracket with internal cable channel, support plate and integrated junction box
WCM3A	Ceiling bracket with ball joint
WCM5A	Ceiling bracket with ball joint
WCM4A2	Ceiling bracket with internal cable channel
WFWCA	Column mount with ball joint
OWBIP1	Kit special gasket to allow protection IP66 for WBOVA2 and WCM4A2
PTH300	Pan&Tilt series
PTH900	Pan&Tilt series
VIP5WAS01	Tank 5l, 230V AC washer pump
VIP5WAS02	Tank 5l, 24V AC washer pump
VIP25WAS01	Tank 25l, 230V AC washer pump
VIP25WAS02	Tank 25l, 24V AC washer pump
VIP25WASA01	Tank 25l, 230V AC washer pump, high delivery up 30m (98.4ft)
DTWRX	Optional board for remote control of wiper and water pump of the UPTWAS series

ENVIRONMENT

Indoor / Outdoor
Operating temperature with heater: -20°C / +50°C (-4°F / +122°F)
Resistant to the salt-air fog until 1000 hours (according to ISO9227)

COMPLIANCE TO

CE according to EN61000-6-3, EN 60065, EN50130-4
IP66 according to EN 60529 with cable glands
IP66 according to EN 60529 with special gaskets and bracket with internal cable channel
IP54 according to EN 60529 with bracket with internal cable channel
IP44 according to EN 60529 with double filter housing

SPARE PARTS LIST

OH0V32SUP	Complete upper body
OBKFIL	Replacement filter kit for double filter housings



Unit Weight:

HOV32K1 3kg / 6.6lb
HOV32K1A085B 4.3kg / 9.5lb

Package Weight:

HOV32K1 3.4kg / 7.5lb
HOV32K1A085B 4.8kg / 9.9lb

Package Dimension (BxHxL):

HOV32K1 19.5x14.5x 52.8cm / 7.7x5.7x20.8in
HOV32K1A085B 19.5x27x52cm / 7.7x5.7x20.8in

Master Carton:

HOV32K1 4 units
HOV32K1A085B 6 units