

- Indoor/Outdoor installations
- Extruded aluminium body epoxy painted
- Hinged, removable body
- Elegant design
- Wide range of accessories available
- Weatherproof standard IP66



HEA30K

HEA30D

Sealed housings for indoor and outdoor use, in modern design. The size of the housing makes it ideal for containing CCD cameras with fixed lenses and compact zooms. Constructed in extruded die-cast aluminium, it is provided with an innovative opening system which allows access to the housing's interior; the body and the sunshield slide forward and hang in place, while the unit remains fixed allowing access to the camera from all angles. A tight seal is ensured by EPDM-rubber gaskets and by 1 PG9 and 1 PG11 cable glands with their specific gaskets. A complete range of accessories is available including: sunshield, normal or fan-assisted heating, blower kit and power supply for the camera. Further, it is also possible to install a blower including an air filter replacing one of the cable gland.

The accessories are supplied factory installed or as a simple upgrade kit. Due to its refined design, HEA is particularly suitable for indoor installations.

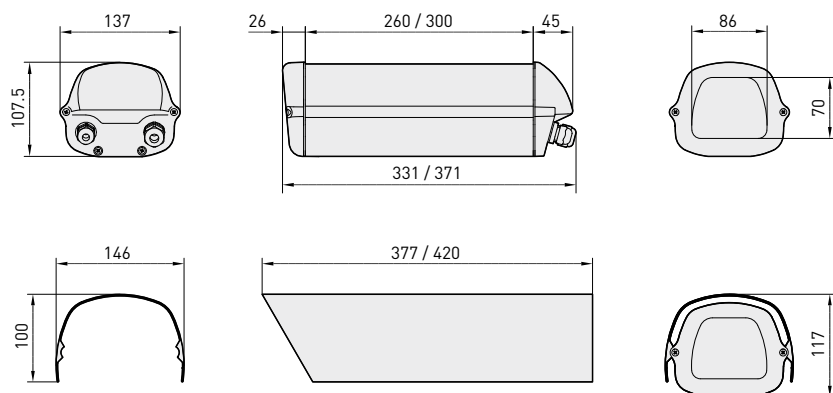

The values are in millimeters.

TECHNICAL DATA

Model	Sunshield	Heater 115/230V AC	Heater 12V DC/24V AC	Fan assisted heater 24V AC	Blower 230V AC with thermostat and filter	Blower 24V AC with thermostat and filter	Max consumption
HEA26D0A000							
HEA26K0A000	•						
HEA26K1A000	•	•					40W
HEA26K2A000	•		•				20W
HEA30D0A000							
HEA30K0A000	•						
HEA30K1A000	•	•					40W
HEA30K2A000	•		•				20W
HEA30K1A011	•	•*			•		44W
HEA30K2A012	•		•*			•	24W
HEA30K2A015	•			•			24W

* The housing must have the same supply as the blower.

GENERAL

Die-cast aluminium back and front cover plates and internal slide

Extruded aluminium body and external slide

Epoxypolyester powder painted colour RAL9002

Stainless steel external screws

Supplied with instruction manual, desiccant bag, accessories for camera and lens mounting

MECHANICAL

2 removable cable glands: 1xPG9 and 1xPG11

Glass window (BxH): 86x 70mm (3.4x2.8in)

Internal usable area (BxH): 84x70mm (3.3x2.7in)

Internal usable length without accessories

HEA26 260mm (10.2in)

HEA30 300mm (11.8in)

Internal usable length with heater

HEA26 180mm (7.0in)

HEA30 220mm (8.7in)

Internal usable length with heater and/or power supply

HEA26 165mm (6.4in)

HEA30 210mm (8.3in)

ELECTRICAL

Heater Ton 15°C+/-3°C (59°F +/-5°F) Toff 22°C+/-3°C (71°F +/-5°F)

- IN 12V DC/24V AC, consumption 20W max

- IN 115/230V AC, consumption 40W max

Blower kit with thermostat air filter, Ton 35°C+/-3°C (95°F+/-5°F) Toff 20°C+/-3°C (71°F+/-5°F) and back cover

- IN 12V DC, consumption 4W max

- IN 24V AC, consumption 4W max

- IN 230V AC, consumption 4W max

Camera power supply

- IN 230V AC - OUT 12V DC, 50Hz, 400mA

- IN 230V AC - OUT 24V AC, 50Hz, 400mA

ACCESSORIES

OHEAS26A000 Sunshield for HEA26

OHEAS30A000 Sunshield for HEA30

OHEH01 Heater 12V DC/24V AC

OHEH02 Heater 115/230V AC

OHEAVF1A Blower kit with thermostat air filter IN 12V DC

OHEAVF2A Blower kit with thermostat air filter IN 24V AC

OHEAVF3A Blower kit with thermostat air filter IN 230V AC

OHEPS05 Camera power supply IN 230V AC - OUT 12V DC

OHEPS06 Camera power supply IN 230V AC - OUT 24V AC

OHEGBB Weatherproof junction box IP55

IR50 IR illuminator 50W

RELATED PRODUCTS

WBMA Wall bracket with ball joint

WCM3A Ceiling bracket with ball joint

WCM5A Ceiling bracket with ball joint

WFWCA Column mount with ball joint

PTH300 Pan&Tilt series

PTH900 Pan&Tilt series.

ENVIRONMENT

Indoor / Outdoor

Operating temperature with heater: -20°C / +50°C (-4°F / +122°F)

Resistant to the salt-air fog until 1000 hours (according to ISO9227)

COMPLIANCE TO

CE according to EN61000-6-3, EN 60065, EN50130-4

IP66 according to EN 60529 with cable glands

SPARE PARTS LIST

DOTHE02 Spacers for camera and lens

OHEAMAN Cable glands, gaskets and screws

OHEAFA04 Front cover with screws and gaskets

OHEAFP04 Back cover with cable glands screws and gaskets



Unit Weight:

HEA26K1 2.5kg / 5.5lb

HEA30K1 2.8kg / 6.2lb

Package Weight:

HEA26K1 2.8kg / 6.2lb

HEA30K1 3.0kg / 6.6lb

Package Dimension (BxHxL):

HEA26K1 15.5x14x43cm / 6.1x5.5x16.9in

HEA30K1 15.5x14x43cm / 6.1x5.5x16.9in

Master Carton:

HEA26K1 10 units

HEA30K1 10 units